

A SIR Model for the Induction Analysis of a Company

Xiao Ni

Ningbo Xiaoshi High School, Ningbo, 315101, China

lum4831@163.com

Abstract. We notice the situation that when applicants are qualified and have the willingness to seek a job, the appraises of employees already in the company will have a large impact on applicants' decisions of whether to become a member of this company or not. We believe that positive appraises will encourage the applicants to enter while negative appraises will discourage applicants. On the basis of this fact, in this paper we propose a compartmental model including the applicants population, the employed population and the resignation population. Several differential equations are set up and disease-free equilibrium is calculated. After the calculation of R_0 , we complete sensitivity analysis which leads to the conclusion. The conclusion suggests that either decreasing the progression rate from applicants to employees who have negative appraises or increasing the progression rate from employees with negative appraises to employees with positive appraises can decrease the population of negative states.

Keywords: company, SIR model, transmissions, basic production number.

1. Introduction

Finding a job is considered as one of the most important things in one's whole life. Still, there are some people who are unemployed. Researches have shown that there is a huge difference between unemployment rate in countries located in Africa and those located in Europe. The World Bank 2020 data show that South Africa has the highest unemployment rate—29.2% in the world while the unemployment rate in Europe is 7.0%, far less than that in South Africa [1, 2]. It is believed that there are many factors influencing unemployment rate. Because of COVID-19, unemployment rate increased significantly throughout the world.

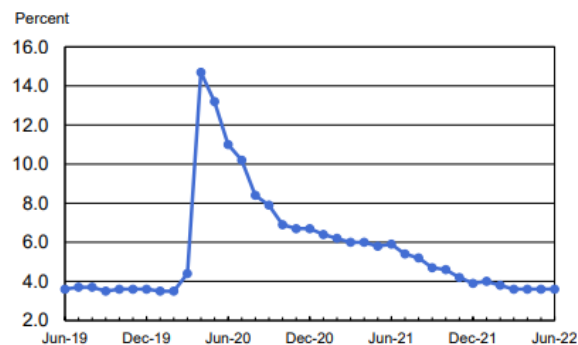

Figure 1. Unemployment rate in U.S. from June 2019 to June 2022 [3].

This chart is a motivation of this article. When COVID-19 suddenly burst, unemployment surged from 3.6% to up to 14.7%. Even without COVID-19, the normalization of increasingly fierce competition due to internalization of competition also affects the unemployment at a large scale. Based on the above reasons, seeking jobs is becoming a serious problem. It is also believed that companies are facing severe challenges. In China, especially for private enterprises, private enterprises' average capital and production scale only accounts for a small percentage of the total economy [4]. In order to strengthen companies, attracting talents can replenish fresh blood for the company and contribute to enhance the creativity and competitive ability. In China, the current urban-rural dual structure causes talent loss in rural areas which further widens urban-rural gap and leads to a vicious spiral [5]. Since seeking jobs is bilateral, companies have to deal with Talent Loss problem and try their best to attract more talents to enter the company. Thus, building a model on subdivision of specific population in a company has scientific significance.

The SIR model is one of the simplest forms of compartmental models. Its variants are widely used in modelling infectious diseases. Moreover, it can also contribute to other fields. As discussed in the first paragraph, reducing unemployment rate is a global challenge. AK Misra and Ak Singh used a simple compartmental model with three variables: numbers of unemployed, temporarily employed and regularly employed people [6]. Gulbanu Pathan and P.H.Bhathawala further proposed an improved SIR model to discuss the unemployment situation accompanied by the outbreak of diseases. The results revealed that decreasing unemployment required high self-employment and efforts made in creating new vacancies. They chose four variables: number of unemployed persons, number of employed persons, number of present jobs in the market and number of newly created vacancies [7]. Giorgos Galanis and Adam Hanieh built a SIDR model with four variables: susceptible, infected, recovered and diseased to quantify the social determinants including employment and corporate them into modelling of COVID-19 [8].

On the basis of traditional SIR model, this article further develops the elements contained in SIR model and is written from the perspective of the company. Progression between applicants and employees with different appraises is believed to have the identity of infectivity which means the progression population is determined by population on both sides. Employees population are divided into those who have positive appraises and those who have negative appraises. The leaving situation is also considered to include those who normally retire from the company and those who leave the company and have opportunity to change their company. Additionally, progression rate from applicants to different states of employees is distinguished. Through theoretical analysis, we calculate the explicit solution of R_0 . By analyzing the astringency of the model due to different values of R_0 , we do sensitivity analysis. Finally, we discover that it is very important to reduce the progression rate from applicants to employees who have negative appraises. The most effective way is to reduce the population of employees with negative appraises itself. Alternatively, increasing the progression rate from who have negative appraises to employees who have positive appraises also serve this role by doing the same thing. The result has certain enlightenment for the company to solve the problem of talent loss and attract talents.

The paper is organized as following: Chapter II introduces the preliminary of the SIR model and its variants. In Chapter III, we formulate the research question and further propose a framework to arrange all transmissions and reconfigure them into transmissions that are from positive to negative expressed through a matrix and other transmissions expressed through a matrix. R_0 is then calculated. In Chapter IV, we conduct sensitivity analysis on impact of different parameters on R_0 and discuss how can these parameters be changed through the company's reaction. In Chapter V, conclusions are made as a summary of this article.

2. Preliminary

The SIR model is the abbreviation of the Susceptible-Infected-Recovered model, each representing a state in a normal infectious disease. Due to the infectivity identity of infectious diseases, transmissions between different states can be quantified into time-dependent differential equations and through the calculations one is able to find the disease-free equilibrium.

The origin of SIR model was first proposed by Ronald Ross in his article "An application of the

theory of probabilities to the study of a priori pathometry” published in 01 February 1916. Ross pointed out that time-dependent differential equations could be used in explaining the reasons why infectious diseases were classified into three groups: diseases that “fluctuate comparatively little from month to month”, diseases that “flare up in epidemics in frequent levels” and diseases that “disappear entirely after periods of acute epidemicity” on the basis of rate of infection, the frequency of outbreaks, and the loss of immunity [9].

Based on traditional SIR model, other modifications add in new variables including birth rate and death rate. According to the classification of infectious diseases, the SIS model is built based on the assumption that people do not develop long-term immunity to the disease. The SI model is given at the situation of no removal will take place in I which indicates that in the long run, all individuals will be affected. The SIRV model has further considerations on the the decisive role of vaccines in curbing infectious diseases. Apart from these models, the SICR model, the SEIR model and the SEIS model all target to specific classification of infectious diseases. Beyond that, the SIR model is combined with varieties of mathematical models to exploit its potential contributions [10].

3. Results

For illustration purpose, the value of these parameters are assumed.

Table 1. Population variables and parameter description (continue).

Population variables	Interpretation	Value
S	The population of applicants	/
I_p	The population of employees who have positive appraises	/
I_n	The population of employees who have negative appraises	/
R_o	The population of former employees who have been retired	/
R_s	The population of former employees who leave the company because of subjective reasons	/
Parameters	Intepretation	Value (per year)
B	Progression rate from employees who have negative appraises to employees who have positive appraises	0.5
b'	Progression rate from employees who have positive appraises to employees who have negative appraises	0.5

Table 1. (continued).

μ	Progression rate from applicants to former employees who leave the company because of objective reasons	0.3
μ'	Progression rate from employees who have positive appraises to former employees who leave the company because of subjective reasons	0.2
μ''	Progression rate from employees who have negative appraises to former employees who leave the company because of subjective reasons	0.5
γ	Progression rate from former employees who leave the company because of subjective reasons to former employees who have been retired	0.2

β_p	Progression rate from applicants to employees who have positive appraisals	0.3
β_n	Progression rate from applicants to employees who have negative appraisals	0.7

Before presenting the model, for the sake of simplicity, several assumptions are made:

(A1) All applicants considered in this article meet the company's recruitment standards and their personal identities are ignored.

(A2) Applicants can only receive information from employees rather than other routines so that their behavior is only affected by employees' appraisals.

(A3) Issues such as aging are not considered. The retirement rate is assumed to be constant.

(A4) The retirement state is considered as the final state without any removal.

(A5) Due to psychological factors called the negative bias, β_n is expected to be larger than β_p [11].

The compartmental model in this article can be regarded as a SEIV model. It is composed of three main states: applicants, employees and former employees. There are two main transmissions: (a) from applicants to employees (b) from employees to former employees.

Based on the assumptions listed above, the transmissions from applicants to employees are mostly influenced by the appraisals given by employees in the company. Thus, the population of companies can be divided into two groups: employees with positive appraisal I_p and employees with negative appraisal I_n . Both population of two different states of employees have the possibility to leave the company. The resignation situation can be further separated because of different resignation reasons. Employees will leave the company either for objective reasons, such as physical injury and aging reasons, or subjective reasons, such as wages and relationship with other employees so that the resignation population is divided into two variables: R_o and

R_s representing objective reasons and subjective reasons respectively. In this article, R_o is regarded as the ending state because it is believed that every person in the population will retire because of aging reasons and never come back into the flow. Its duty corresponds with Vaccine in the SEIV model.

As explained in the assumptions, the transmissions from S to I are determined by the population on both sides, which is similar to the circumstance in infectious diseases. The progression rate from applicants to employees who have positive appraisals is β_p which is expected to be smaller than the progression rate from applicants to employees who have negative appraisals β_n . To quantify the transmissions, the time-dependent formula of that from S to I_p is $\beta_p S I_p$ and that from S to I_n is $\beta_n S I_n$. Inside the company, employees' attitudes can change over time. The formula of transmissions from I_n to I_p is $b I_n$ and the formula of transmission from I_p and I_n is $b' I_p$. b and b' differs as the reason that the environment in the company tends to adjust the employee population into unbalanced appraisals. For the transmissions from employees population to R_o , they share the same progression rate μ since it is not affected by their appraisals. The transmissions can be expressed as μI_p and μI_n respectively. By contrary, the progression rate from employees to R_s is different depend on different appraisals. While it cannot be denied that even employees with positive appraisals can leave the company because of subjective reasons, transmissions between I_p and R_s still exist. However, μ' is expected to be far less than μ'' . Further more, a part of population of R_s will finally transfer to the ending state R_o while the rest population return to the human resources markets but they are impossible to apply for the same company again so that this section is seen to be removed from the flowchart.

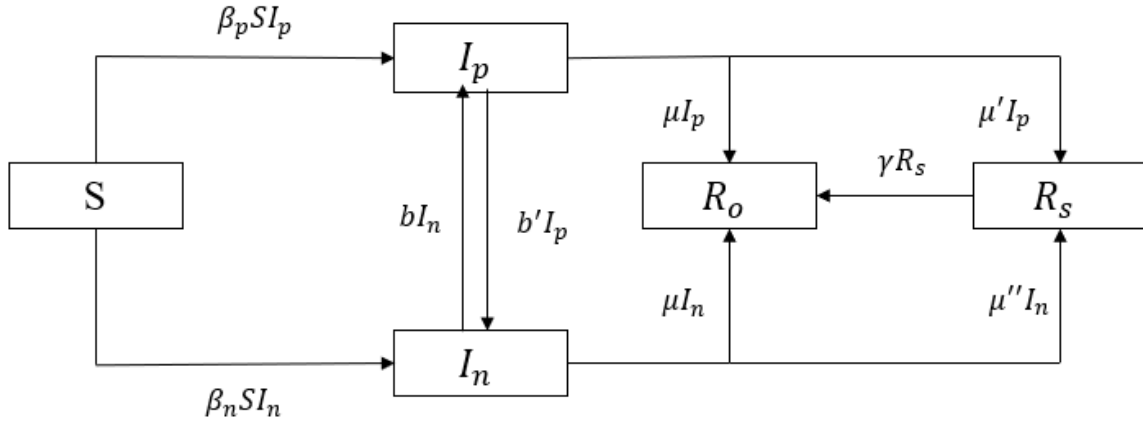

Figure 2. Flowchart of Transmissions for Induction Model.

Based on the above discussion and flowchart in Fig 2, the model is formulated as follows:

$$\left\{ \begin{array}{l} \frac{dI_n}{dt} = \beta_n S I_n + b' I_p - b I_n - \mu I_n - \mu'' I_n \\ \frac{dR_s}{dt} = \mu' I_p + \mu'' I_n - \gamma R_s \\ \frac{dS}{dt} = -\beta_n S I_n - \beta_1 S I_p \\ \frac{dI_p}{dt} = \beta_p S I_p + b I_n - b' I_p - \mu I_p - \mu' I_p \\ \frac{dR_o}{dt} = \mu(I_p + I_n) + \gamma R_s \end{array} \right. \quad (1)$$

In this article, I_n and R_s are considered as negative situations. In order to reach the disease-free equilibrium, let I_n and R_s be zero and all the differential equations be zero to ensure the stability.

Let

$$F = \begin{pmatrix} \beta_n S I_2 + b' I_p \\ \mu' I_p \\ 0 \\ 0 \\ 0 \end{pmatrix} \text{ and} \quad V = \begin{pmatrix} b I_n + \mu I_n + \mu'' I_n \\ -\mu'' I_n + \gamma R_s \\ \beta_n S I_n + \beta_1 S I_p \\ -\beta_1 S I_p - b I_n + b' I_p + \mu I_p + \mu' I_p \\ -\mu(I_p + I_n) - \gamma R_s \end{pmatrix} \quad (2)$$

An equilibrium solution with $I_n = R_s = 0$ has the form $x_0 = (0, 0, S, 0, 0)'$, where S is any positive solution satisfying the equation. Without loss of generality, assume

$S = 1$ is a disease-free equilibrium.

Then, through partial derivative,

$$\mathcal{F} = \begin{pmatrix} \beta_n & 0 \\ 0 & 0 \end{pmatrix} \text{ and } \mathcal{V} = \begin{pmatrix} b + \mu + \mu'' & 0 \\ -\mu'' & \gamma \end{pmatrix} \quad (3)$$

Giving that:

$$\mathcal{V}^{-1} = \frac{1}{(b + \mu + \mu'')\gamma} \begin{pmatrix} \gamma & 0 \\ \mu'' & b + \mu + \mu'' \end{pmatrix} \quad (4)$$

If x_0 is a DFE of the model, x_0 is locally asymptotically stable if $\mathcal{R}_0 < 1$ and unstable if $\mathcal{R}_0 > 1$ where \mathcal{R}_0 is defined as the follow:

$\mathcal{R}_0 = \rho(FV^{-1})$ which denotes the spectral radius of matrix FV^{-1} .

Finally, through calculations, $\mathcal{R}_0 = \frac{\beta_n}{b + \mu + \mu''}$

4. Sensitivity analysis

MATLAB is used to graph these figures.

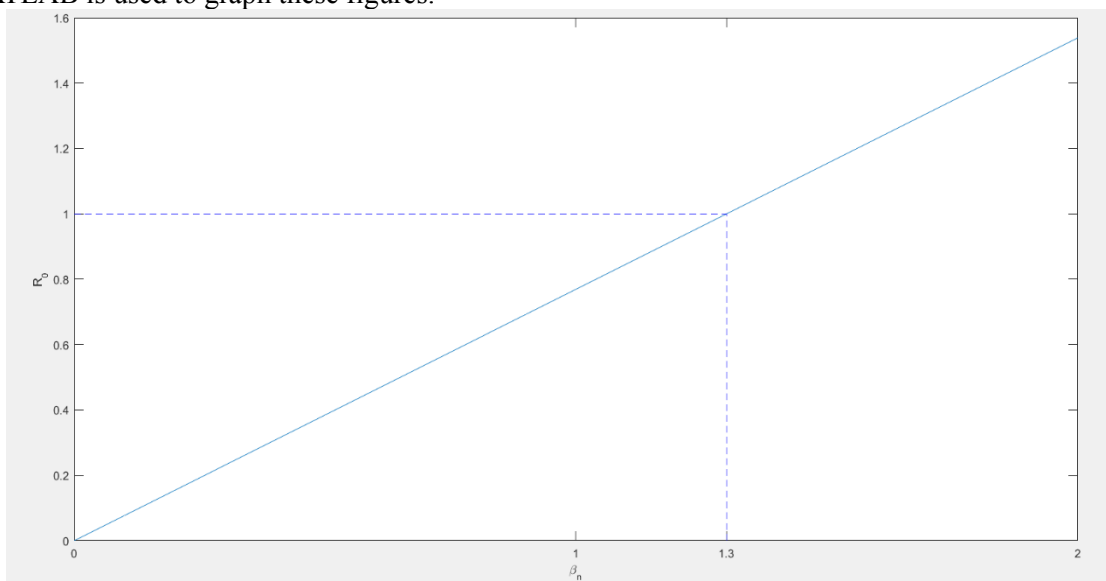

Figure 2. \mathcal{R}_0 and β_n .

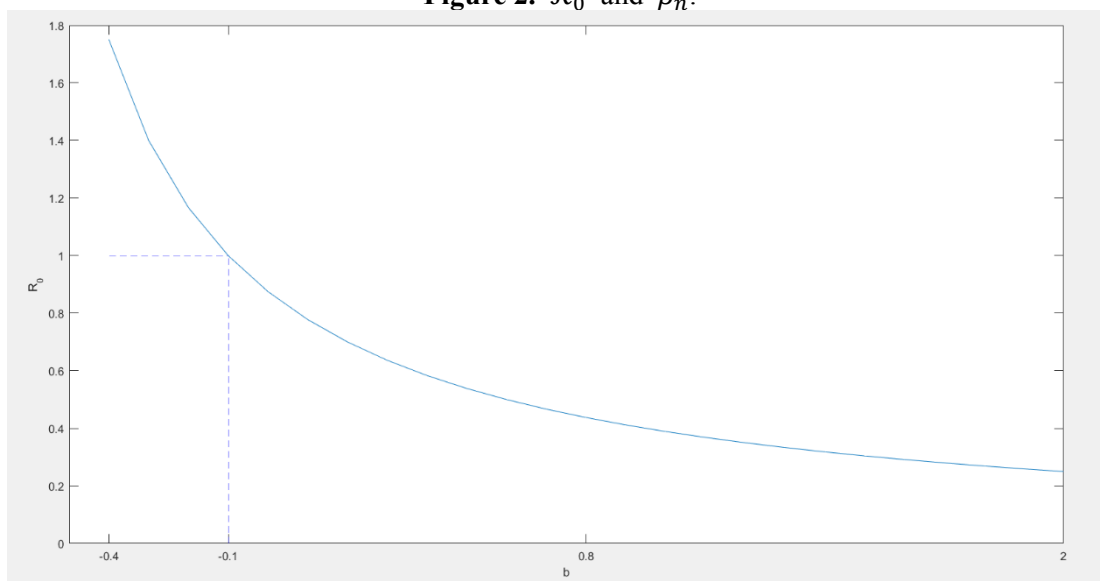

Figure 3. \mathcal{R}_0 and b .

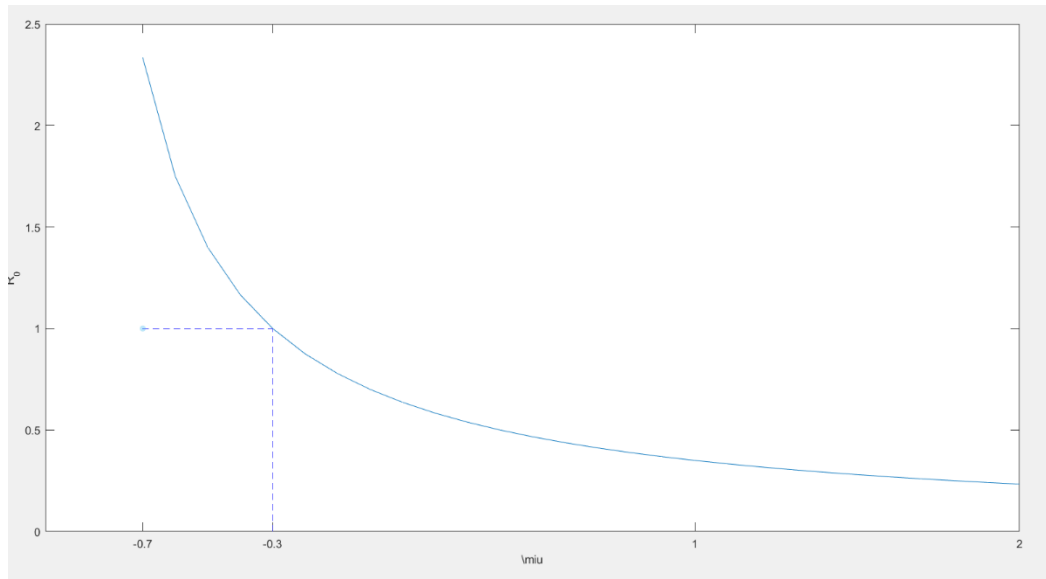

Figure 4. \mathcal{R}_0 and μ .

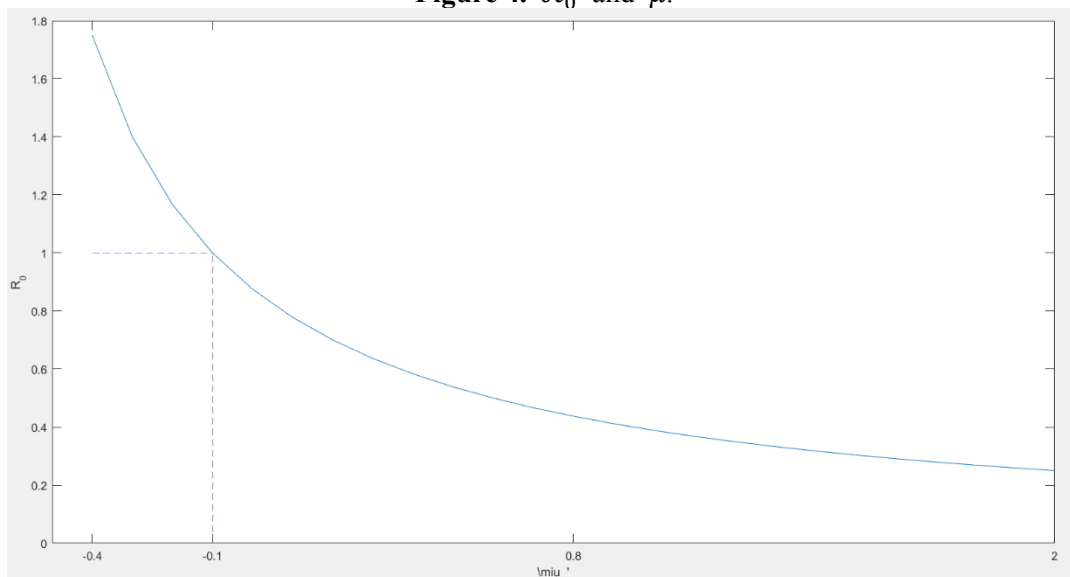

Figure 5. \mathcal{R}_0 and μ'' .

In these figures, the relationship between each constant and \mathcal{R}_0 is shown, and points at $\mathcal{R}_0 = 1$ are noted.

Based on these figures, it is discovered that for positive variables b , μ and μ'' , \mathcal{R}_0 is always smaller than one which indicates that the DFE of the model is stable. However, there are still differences in the gradient of these three figures. Through the graph, it can be seen that the gradient of curves in Fig 2 and Fig 4 are the same, which shows that roles of changing β_n is the same as roles of changing μ'' . The absolute value of gradient of the curve in Fig 3 is larger than those of the other two, so changes on μ may have larger impact on keeping the DFE stable. All of the gradients of these three curves are negative. Increasing these constants can contribute to the stability of the company. For the first figure, the gradient is a positive constant which shows that decreasing the constant can make the company more stable.

5. Conclusion

The results imply that in order to reduce the population of I_n and R_s , the company should focus more on reducing the progression rate from applicants to employees who have negative appraises and raise the progression rate from applicants to former employees who leave the company because of objective reasons. To reach the first goal, the company should enhance the publicity of the company and improve the company's management model so that there will be more I_p and less I_n in the company, which will lower the progression population from S to I_n and raise the progression population from S to I_p simultaneously. To reach the second goal, the company should improve the welfare system. Though one cannot change the problem of retiring due to age, a better welfare system will ensure the employees' health and make them feel less stressed. It can help the company to avoid retiring due to physical injury or mental illness. In addition, increasing the progression rate from employees who have negative appraises to employees who have positive appraises and the progression rate from employees who have negative appraises to former employees who leave the company because of subjective reasons also have positive effect. For the first factor, the suggestions discussed above still work, and taking employees' needs seriously can convert employees with negative appraises to employees with positive appraises as well. Considering from real life, the second factor cannot be controlled artificially.

References

- [1] "Unemployment, Total (% of Total Labor Force) (Modeled ILO Estimate) - European Union | Data." Unemployment, Total (% of Total Labor Force) (Modeled ILO Estimate) - European Union, data.worldbank.org/indicator/SL.UEM.TOTL.ZS?end=2020&locations=EU&start=1991. Accessed 11 July 2022
- [2] "Unemployment by Country 2022." Unemployment by Country 2022, worldpopulationreview.com/country-rankings/unemployment-by-country. Accessed 11 July 2022
- [3] "Economic News Releases : U.S. Bureau of Labor Statistics." THE EMPLOYMENT SITUATION — JUNE 2022, 15 Feb. 2017, www.bls.gov/bls/newsrels.htm
- [4] Zhonghui, Wang. "Private enterprise in China: an overview." *Journal of communist studies* 6.3 (1990): 83-98
- [5] J Clerk Maxwell, *A Treatise on Electricity and Magnetism*, 3rd ed., vol. 2. Oxford: Clarendon, 1892, pp.68–73
- [6] Wei, ShanYuan, RenDe Yang, and Hua Xiang. "Talent loss and new countryside construction: thinking about rural talents loss in China." *Guizhou Agricultural Sciences* 9 (2009): 250-252
- [7] Misra, A. K., and Arvind K. Singh. "A mathematical model for unemployment." *Nonlinear Analysis: Real World Applications* 12.1 (2011): 128-136
- [8] Pathan, Gulbanu, and P. H. Bhathawala. "Mathematical model of Unemployment-an analysis with delay." *Global Journal of Mathematical Sciences: Theory and Title in Practical* 9 (2017): 225-237
- [9] Galanis, Giorgos, and Adam Hanieh. "Incorporating social determinants of health into modelling of COVID-19 and other infectious diseases: a baseline socio-economic compartmental model." *Social Science & Medicine* 274 (2021): 113794
- [10] Ross, Ronald. "An application of the theory of probabilities to the study of a priori pathometry.— Part I." *Proceedings of the Royal Society of London. Series A, Containing papers of a mathematical and physical character* 92.638 (1916): 204-230
- [11] Kastalskiy, Innokentiy A., et al. "Social stress drives the multi-wave dynamics of COVID-19 outbreaks." *Scientific Reports* 11.1 (2021): 1-12
- [12] Wright, Beatrice A. "Attitudes and the fundamental negative bias: Conditions and corrections." (1988)